

2016

-

## ADJUSTABLE DESK

I designed and made this desk myself when I was at the Cluny Arts et Métiers engineering school. Indeed, I needed a desk that allows me to work both seated and standing because I was already working at that time on many design projects, involving the manufacture of models and prototypes.







# 2021

-

## TOMEIO CHAIRS

A simple and impacting chair. Stackable and lightweight, was the initial brief for this project. This is a perfect chair for the contract market as well as for the personal market. Its distinctive, elegant and honest design gives special character and a touch of modernity to the room or the terrace it is placed.





M&O 2025



FAMILY



2022

-

## TOMEIO VARIATIONS

A simple and impacting chair. Stackable and lightweight, was the initial brief for this project. This is a perfect chair for the contract market as well as for the personal market. Its distinctive, elegant and honest design gives special character and a touch of modernity to the room or the terrace it is placed.



FAMILY



FAMILY



2023

-

ANTON

The Anton series with its delicate, modern and timeless look aims to become a collection of references to furnish the most distinguished and luxurious places. High-quality covers in leather or fabric encase the shell of the back as well as the seat itself.



1:6 SCALE MODEL





# 2023

-

## LOOP COLLECTION

The design was a little bit to cubic and to "Knoll" in the identity. So, I start thinking on how to add more roundness and make it more "Infiniti". And I was thinking at the same time of the constrain of the flat packing .





ARMCHAIR



BENCH & ARMCHAIRS



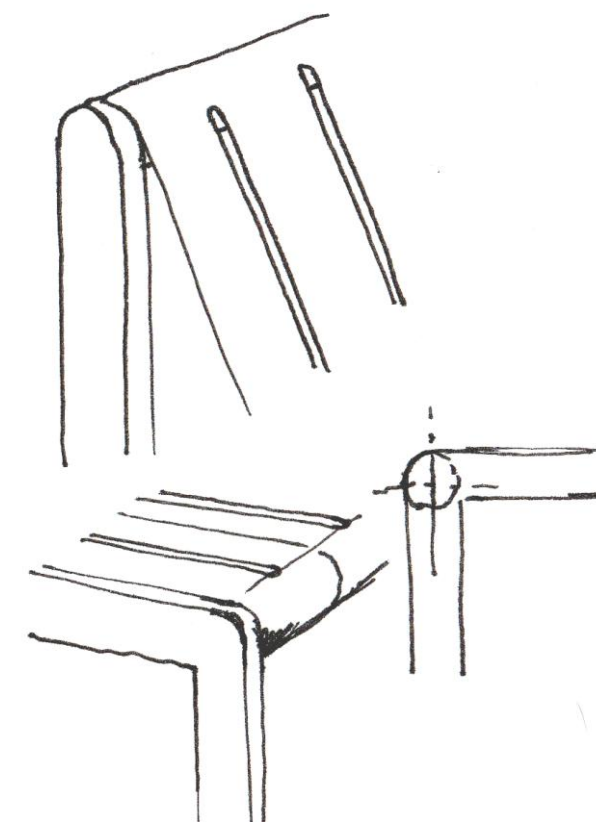

2024

-

RUMO

Rumo is a seating collection, with its sleek and sturdy design, harmoniously combines form and function, reflecting the fundamental principles of the functionalist movement.



## **industrial aesthetic**

I'm fascinated by the manipulation of metal in industry, whether bent, welded or punched. The challenge of this new design is to exploit the aesthetic possibilities offered by industrial techniques, combining them with a concern for finesse and creativity, to give birth to a chair that combine the rigor of industrial production with the elegance of craftsmanship.

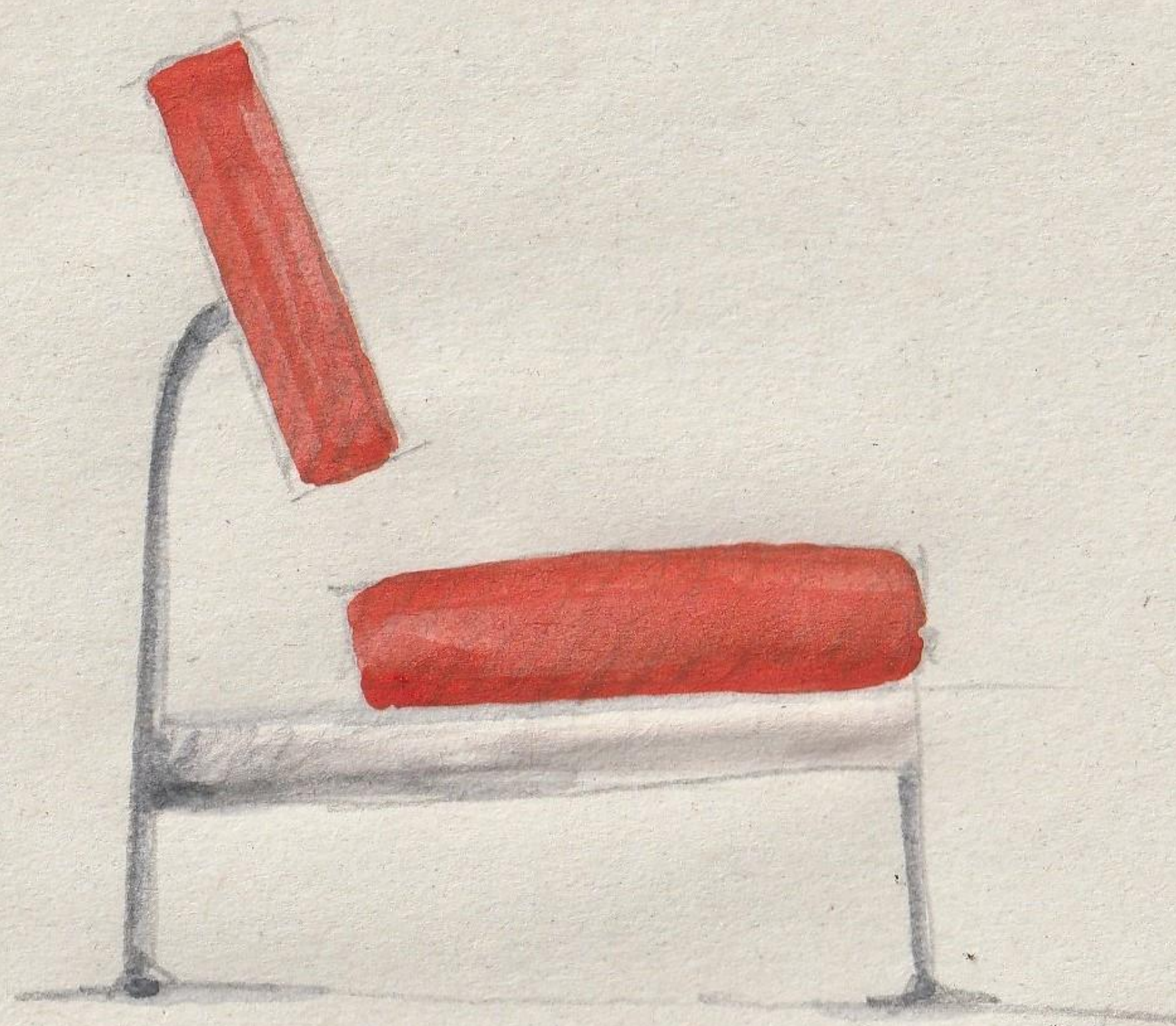

2023

-

DIETER

Dieter is a modular armchair that can be used for indoor and semi-outdoor spaces. This product was thought as an elegant waiting chair in trains stations, airports, hospitals ...etc

*Dieter*



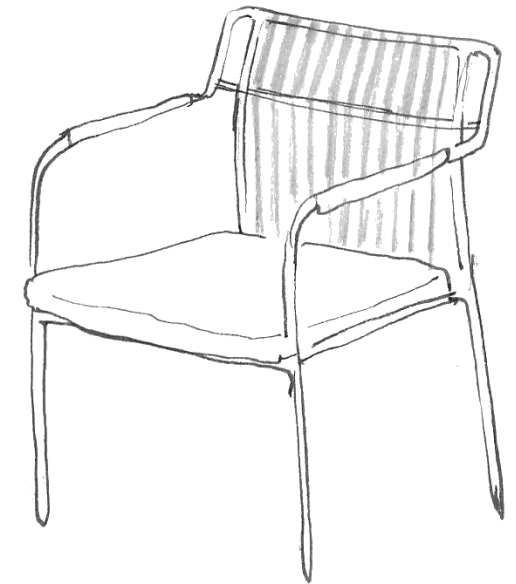

2024

-

BELVEDERE

The belvedere chair is a simple chair with a highly original structure that is unusual for a chair: the back legs rise up to the level of the high back. This creates an original detail that gives the chair a recognizable identity.





# 2023

-

## LOUISE

Louise is inspired by the medallion chairs of the Louis XVI era. Its unique style and simple, robust structure make Louise the perfect chair for both B2B and individual customers. It is a chair designed to be produced industrially and aimed at the mass market. With Louise, everyone will have the opportunity to bring a piece of French history into their homes.





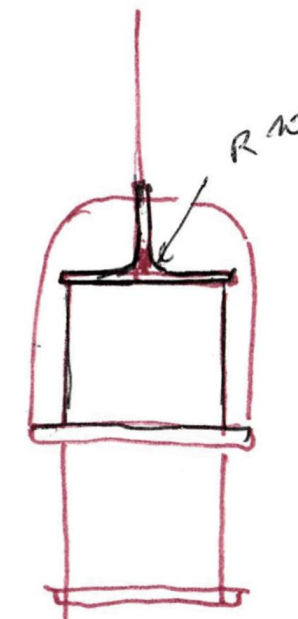

2022

-

MISTRAL

Mistral is a minimalistic lighting, available as a pendant or a table lamp. Its very graphic look recalls of the old oil lamp used in the boats but with a nice and modern touch. This product was thought to be extremely simple in its conception in order to minimize the costs of production.



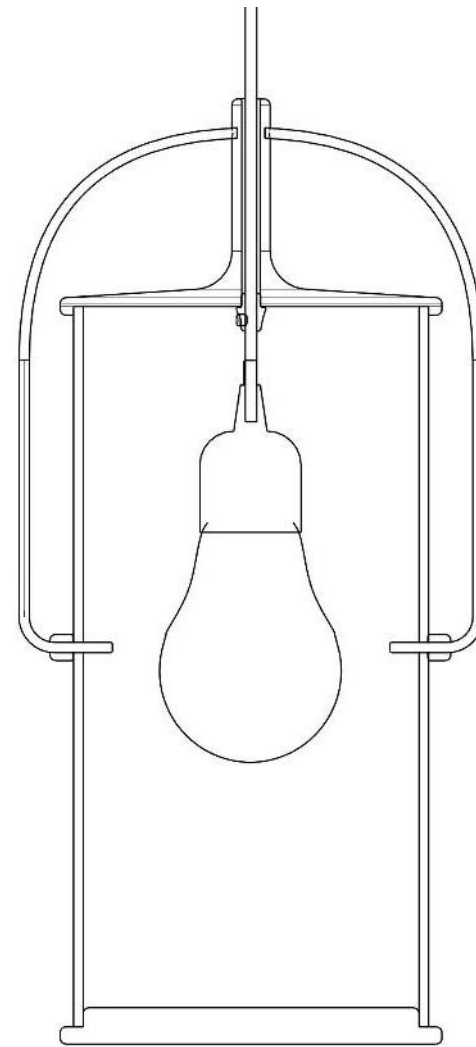
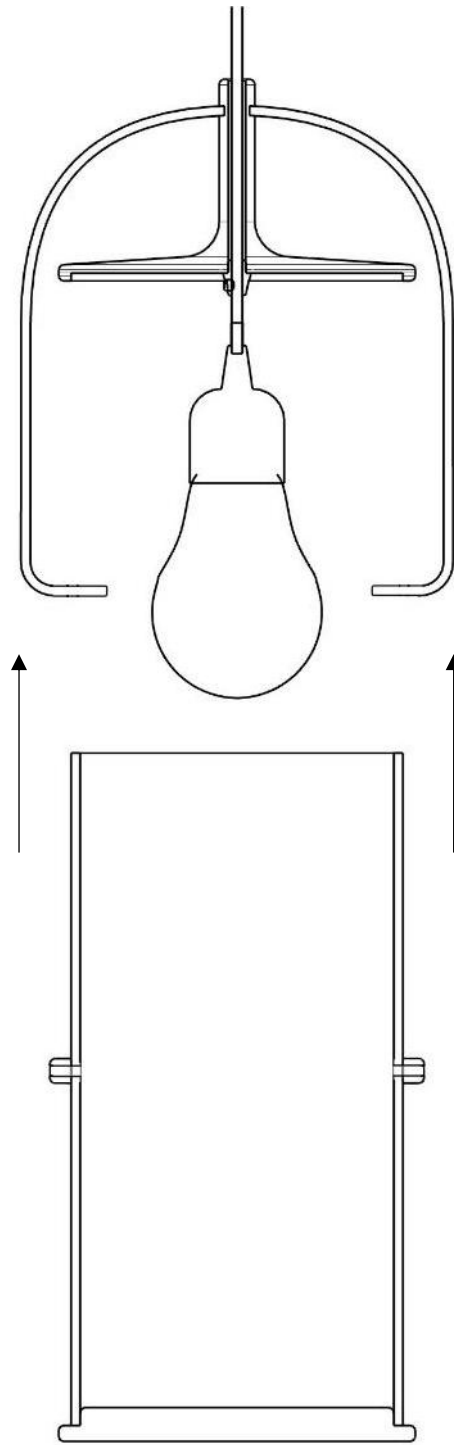

## ASSEMBLY:

Thanks to the simplicity of its conception Elio is ready for industrialization. This is a smart product that makes a strong effect but is not technically complex. The top part and the diffuser can be attached thanks to the metallic branches that are inserted into small wholes in the diffuser

# Demi-Lune

La suspension Demi-Lune est une proposition minimaliste et graphique qui puise son inspiration dans les formes géométriques de la peinture abstraite de début du XX<sup>ème</sup> siècle. Polyvalente et facile à intégrer, cette suspension élégante et originale apportera une touche de modernité à tous les intérieurs.









# 2016

-

## TEO CHAIR

This Outdoor armchair was designed to be very easy to manufacture but with a little interesting design detail which is the backrest that lays on the armrests, This Outdoor armchair was designed to be very easy to manufacture but with a little interesting design detail which is the backrest that lays on the armrests







2020

-

PIXA  
COLLECTION

In the manner of auto progettazione project by Enzo Mari, these pieces of furniture can be made simply with very accessible materials. This collection imbued with a tribal and naive spirit is part of an approach aiming to embrace and celebrate the industrial culture by diverting some of these products. Here, planks of treated pine intended for the construction of outdoor floors are the only component of each of these pieces of furniture.

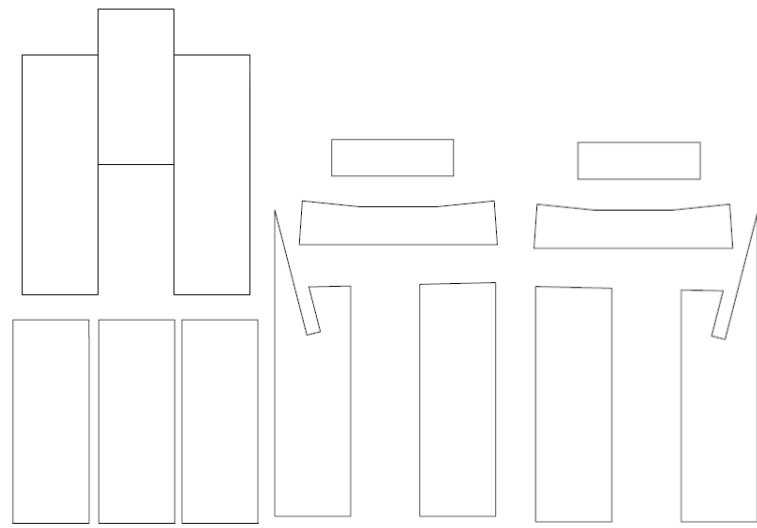

We use the edges as they are. The cutting layout minimizes the rubbish. The planks edges are already chamfered, and the surface is already smoothed. Using a unique plank model allows to simplify the fabrication at the most. Boards of pine intended for the construction of outdoor flooring are the only component of each of these pieces of furniture.





## **PIXA**

In the manner of auto progettazione project by Enzo Mari, these pieces of furniture can be made simply with very accessible materials. This collection imbued with a tribal and naive spirit is part of an approach aiming to embrace and celebrate the industrial culture by diverting some of these products. Here, planks of treated pine intended for the construction of outdoor floors are the only component of each of these pieces of furniture.









# 2024

-

## HELENA

The Hélène collection, comprising a chair with armrest, a simple chair and an armchair, is a seating collection with an innovative design. It took me a long time to sculpt the material to give birth to this new product, which I hope will become a contemporary classic. A product with a strong, sleek design, but also with a singular language of its own.



THE UNIQUE FEATURE OF THIS CHAIR  
LIES IN THE SEAMLESS CONNECTION  
BETWEEN THE LEGS AND THE BACKREST,  
MAKING IT A UNIQUE AND RECOGNIZABLE DETAIL.

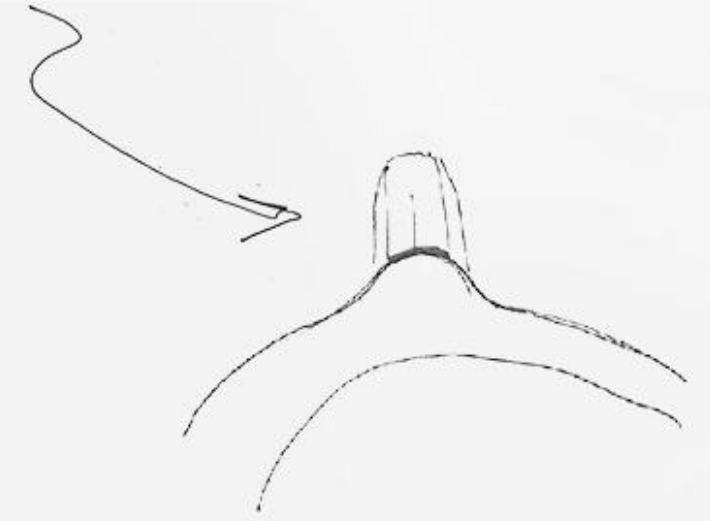

THE BACKREST TURNS ON ITSELF  
LIKE A RIBBON.

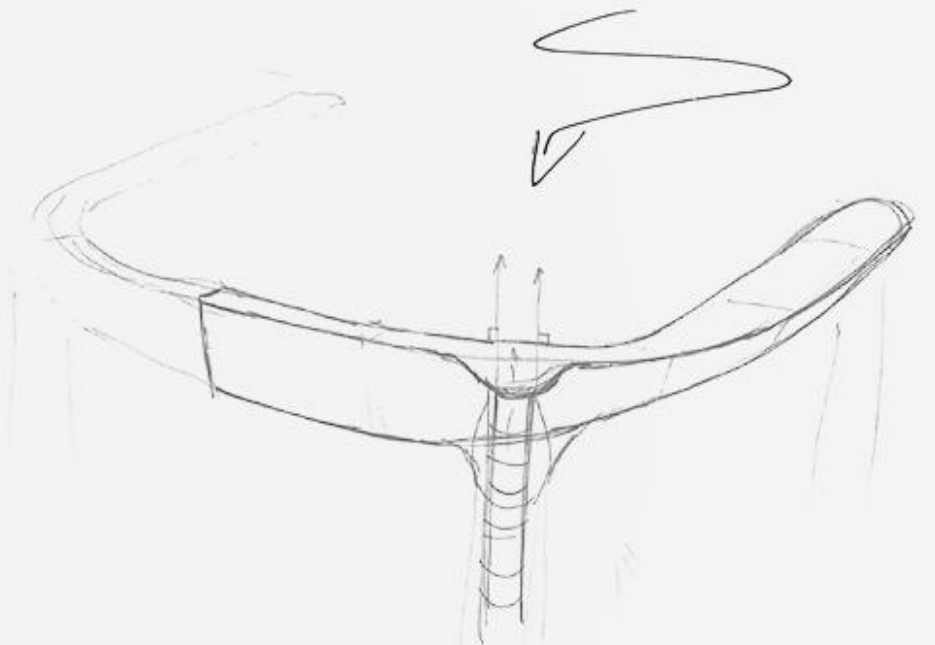







## PROTOTYPE

Thanks to its upholstered fabric backrest that is separate from the seat, this chair offers incredible comfort. We tested it at the Milan show, and all three models - the chair, the armchair and the fauteuil lounge - offer outstanding comfort.



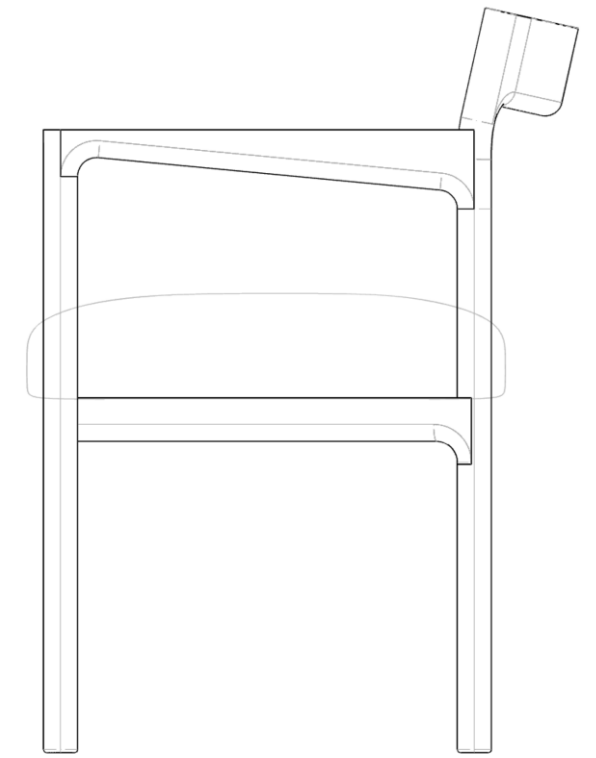

## Chaise Orion

L'accoudoir de forme triangulaire constitue le point de départ de ce projet, le reste de la structure se développe naturellement autour de ce signe distinctif.

*The triangular armrest is the starting point of this project; the rest of the structure naturally unfolds around this distinctive feature.*

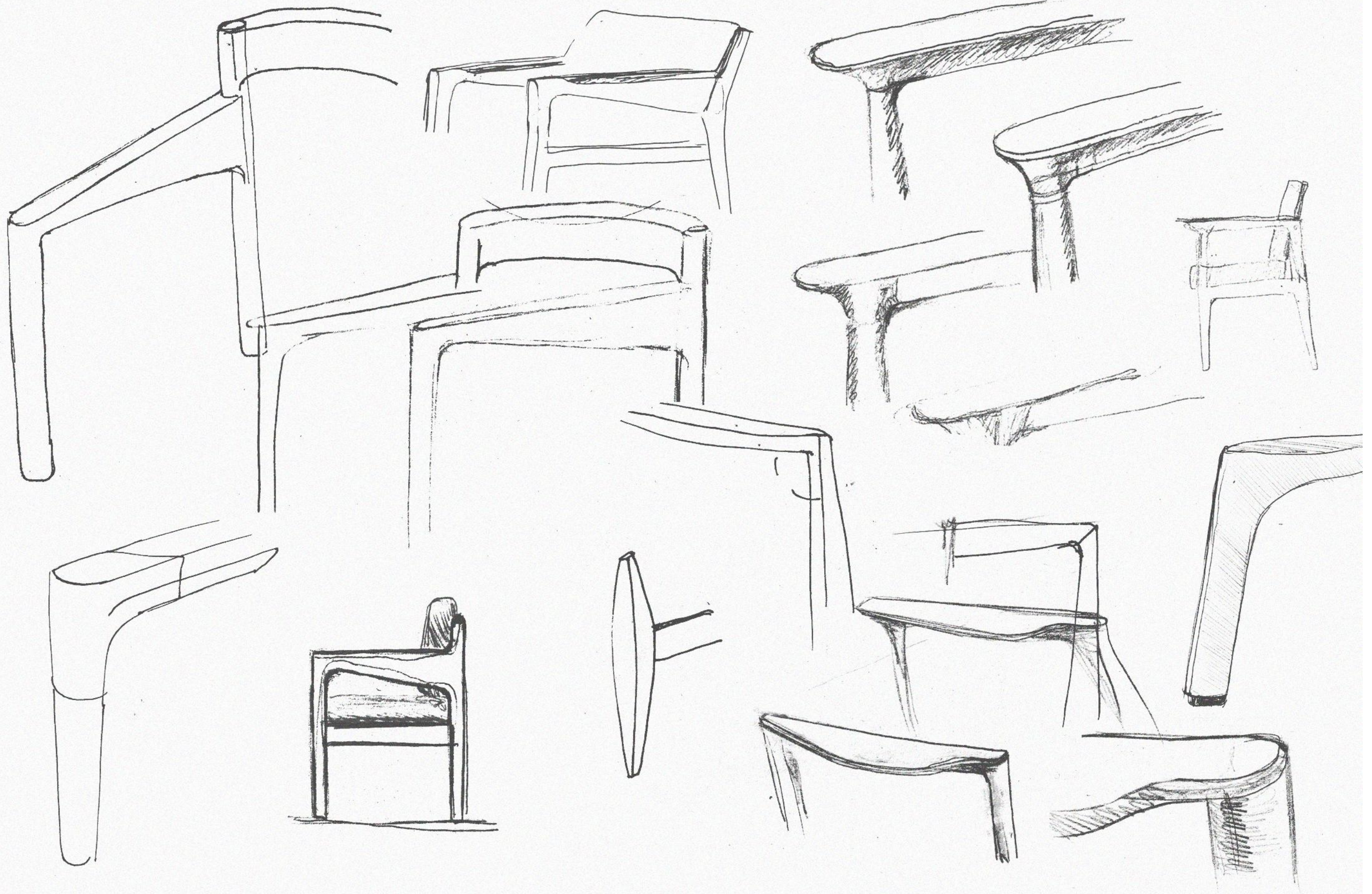



J'ai souhaité respecter des principes de création des objets durables et indifférents aux modes : une chaise intelligente fonctionnelle et robuste, une ligne claire avec des détails élégants, une forme d'évidence visuelle.

*My aim was to adhere to principles of creating durable objects that transcend fleeting trends: a smart, functional, and robust chair, with clean lines and elegant details, a sense of visual clarity.*

Ce projet allie la rigueur du design industriel et la chaleur de la fabrication artisanale. La conception est pensée pour minimiser au maximum le nombre d'éléments. Ce qui permet de diminuer les coûts tout en procurant une légèreté visuelle. Le design est épuré presque aérien.

*This project combines the rigor of industrial design with the warmth of handcrafted production. The design is conceived to minimize the number of components, reducing costs while achieving a visually light feel. The design is refined, almost ethereal.*





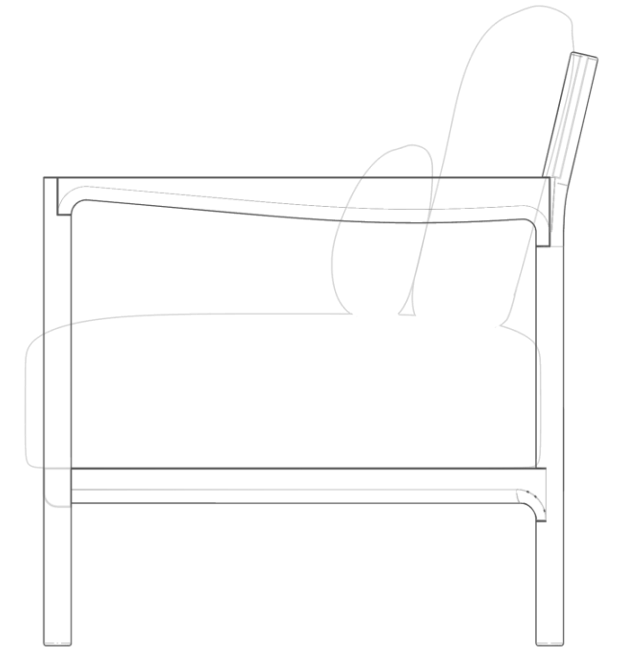

## Fauteuil Orion

Ce projet allie la rigueur du design industriel et la chaleur de la fabrication artisanale. La conception est pensée pour minimiser au maximum le nombre d'éléments. Ce qui permet de diminuer les coûts tout en procurant une légèreté visuelle. Le design est épuré presque aérien.

*This project combines the rigor of industrial design with the warmth of handcrafted production. The design is conceived to minimize the number of components, reducing costs while achieving a visually light feel. The design is refined, almost ethereal.*



Cette chaise est destinée aux espaces les plus modernes comme aux chalets de montagne les plus traditionnels.

*This chair is suitable for both the most modern spaces and the most traditional mountain chalets..*







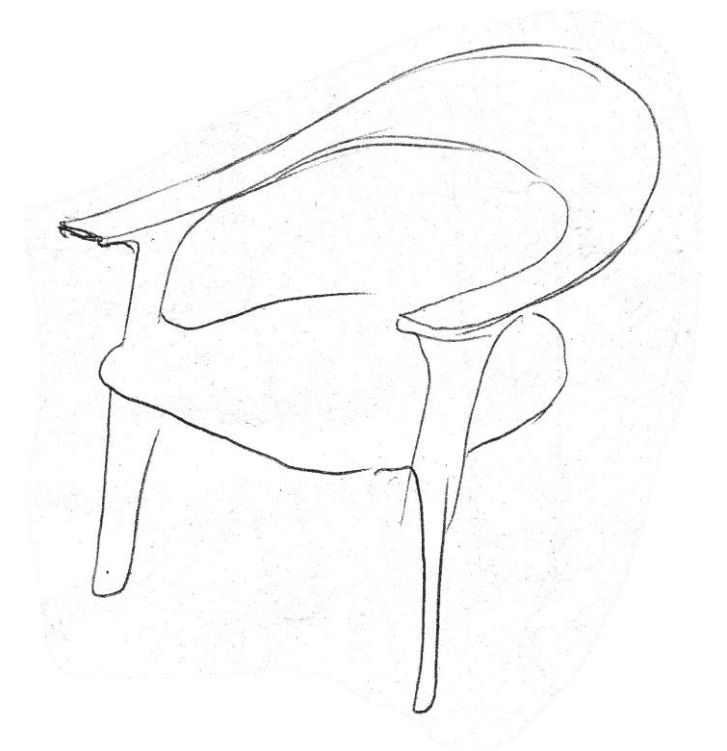

## Chaise Nocta

La chaise Nocta est une réinterprétation d'une chaise bridge « middle-back » d'inspiration scandinave. La conception d'un modèle aux lignes aussi organiques exige une réelle maîtrise des outils de modélisation 3D.

*The Nocta chair is a reinterpretation of a Scandinavian-inspired "middle-back" bridge chair. Designing a model with such organic lines requires true mastery of 3D modeling tools.*

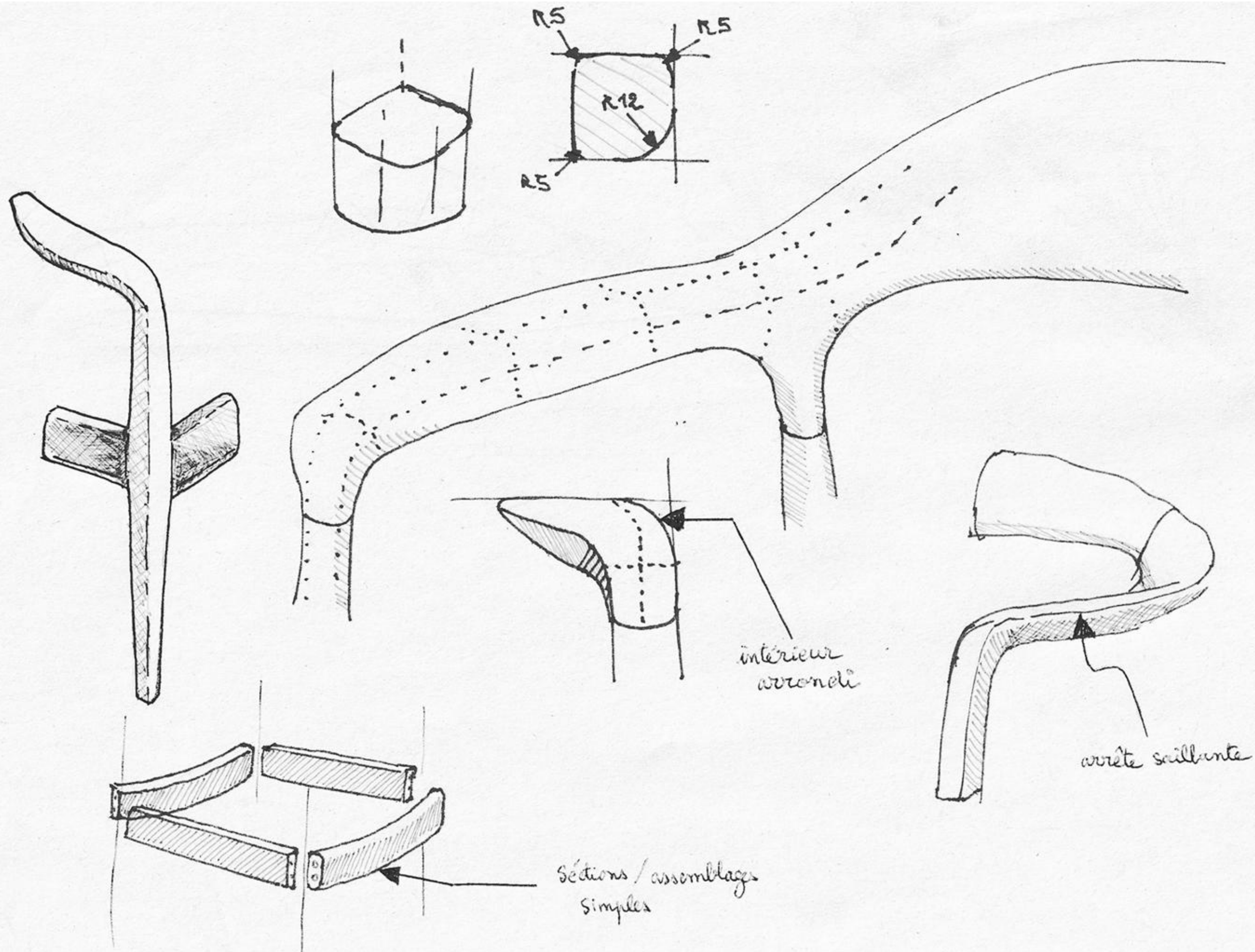

intérieur arrondi

arête saillante

sections / assemblages  
simples





La particularité de cette chaise réside dans le dessin de ses pieds. Leur section carrée, visible depuis l'extérieur, présente des arêtes nettes et saillantes qui dessinent une silhouette précise et découpée. À l'intérieur, les arêtes s'adoucissent pour laisser place à une section arrondie, créant une transition fluide et naturelle avec l'assise et le dossier.

*The chair's distinctive feature lies in the design of its legs. Their square section, visible from the outside, features sharp, prominent edges that create a precise, sculpted silhouette. Inside, the edges soften to form a rounded section, creating a fluid and natural transition to the seat and backrest.*

La chaise oppose ainsi des lignes extérieures tendues et affirmées à des lignes intérieures douces et enveloppantes. Ce contraste lui confère toute son identité et renouvelle avec justesse un modèle souvent copié et décliné.

*The chair thus contrasts taut, assertive exterior lines with soft, enveloping interior lines. This contrast gives it its unique identity and offers a fresh take on a frequently copied and adapted design.*



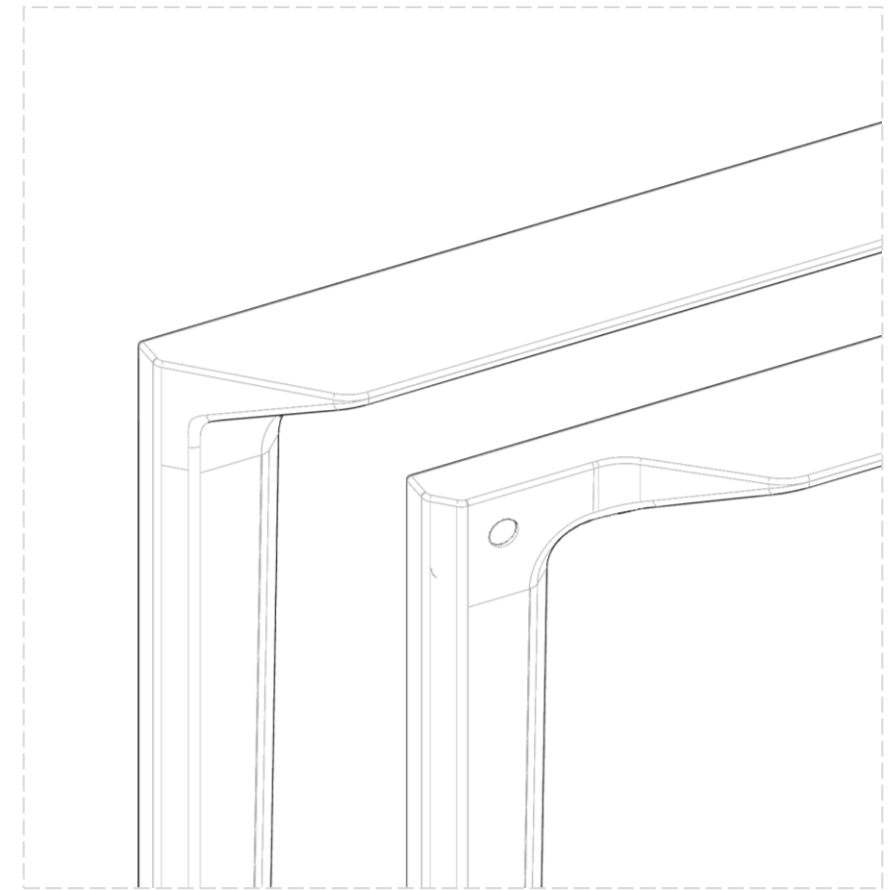

## Fauteuil Uni

Le fauteuil Uni puise son inspiration dans un modèle intitulé University Chair. Ses lignes sont franches, radicales et volontairement rigoureuses, tout en conservant une élégance froide.

*The Uni armchair draws its inspiration from a model called the University Chair. Its lines are clean, radical, and deliberately rigorous, while maintaining a cool elegance.*

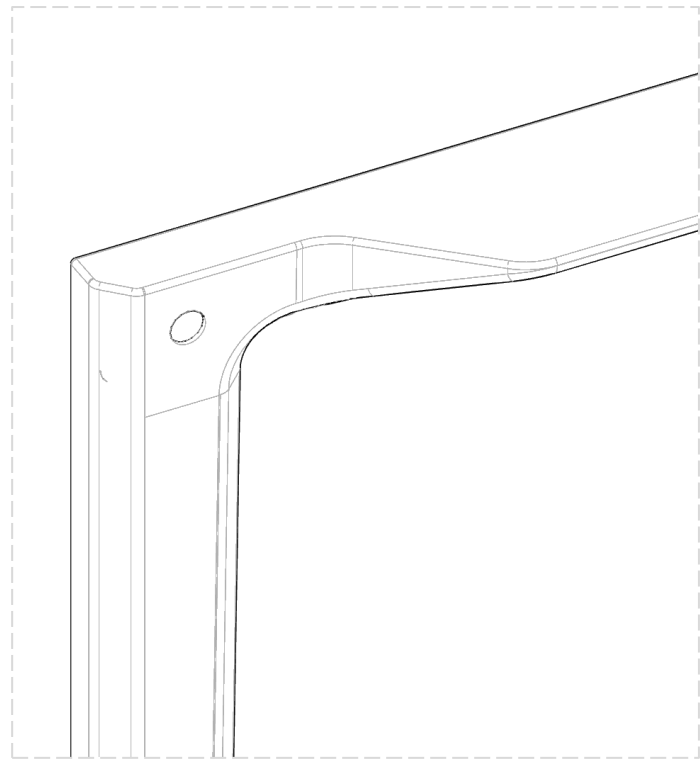

Les courbes et les formes organiques laissent place à des facettes orientées à 0, 45 ou 90 degrés. Je souhaitais utiliser du Hêtre pour la structure, une essence de bois extrêmement dure et lisse. Ce choix de matériau m'a naturellement orienté vers ces lignes saillantes et radicales.

*Curves and organic shapes give way to facets oriented at 0, 45, or 90 degrees. I wanted to use beech for the frame, an extremely hard and smooth wood. This choice of material naturally led me to these striking and radical lines.*







Le fauteuil Uni puise son inspiration dans un modèle intitulé University Chair. Ses lignes sont franches, radicales et volontairement rigoureuses, tout en conservant une élégance froide. Les courbes et les formes organiques laissent place à des facettes orientées à 0, 45 ou 90 degrés. Je souhaitais utiliser du Hêtre pour la structure, une essence de bois extrêmement dure et lisse. Ce choix de matériau m'a naturellement orienté vers ces lignes saillantes et radicales.

*The Uni armchair draws its inspiration from a model called the University Chair. Its lines are clean, radical, and deliberately rigorous, while maintaining a cool elegance. Curves and organic shapes give way to facets oriented at 0, 45, or 90 degrees. I wanted to use beech for the frame, an extremely hard and smooth wood. This choice of material naturally led me to these striking and radical lines.*

# THANK YOU

CONTACT

[www.hugocharlet.com](http://www.hugocharlet.com)  
[hugocharlet@gmail.com](mailto:hugocharlet@gmail.com)  
0033- 6 72 66 66 86